

OP



Assembly: on columns, extension arms, aluminium and steel wall brackets, arm systems with spigot ending $\varnothing 60$ mm, 45 mm deep and on plastic poles type S and SP with spigot ending type „B”

Ingress protection: IP 65 for optical system and for power supply

Material: base - poliamide control gear cover - polycarbonate

Colour: black

Input voltage: 230V AC

Input voltage frequency: 50Hz

Electrical gear cover: mounted on gear frame, magnetic ballast with thermal protection for luminaire 50W-150W, metal halide lamps MH 70W (EL) optionally available with electronic ballast

Sposób montażu: upwards or downwards

Unit volume: 0,01m²

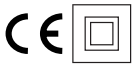

Code	Symbol	Lamp diffuser neck	Power	Luminaire types	Light source type	Unit volume	Net weight
210102	OP S-70W/400	180mm	70W	Atlanta 400, Sphere 400, Klio 400	Sodium E-27	0,14m ²	2,4kg
210103	OP S-100W/400	180mm	100W	Sphere 400	Sodium E-40	0,14m ²	2,6kg
210107	OP MH-70W/400	180mm	70W	Atlanta 400, Sphere 400, Klio 400	Metal halide E-27	0,14m ²	2,4kg
210108	OP MH-100W/400	180mm	100W	Sphere 400	Metal halide E-27	0,14m ²	2,6kg
210115	OP E/Z/400	180mm	23W	Atlanta 400, Sphere 400, Klio 400	Compact fluorescent lamp E-27	0,14m ²	1kg
210202	OP S-70W/450	180mm	70W	Sphere 450	Sodium E-27	0,17m ²	2,7kg
210203	OP S-100W/450	180mm	100W	Sphere 450	Sodium E-40	0,17m ²	2,9kg
210215	OP E/Z/450	180mm	23W	Sphere 450	Compact fluorescent lamp E-27	0,17m ²	1,3kg

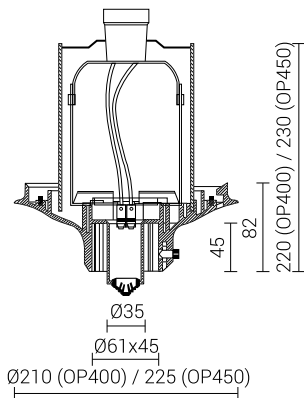

Directive: 2014/35/UE (Official Journal of the UE L 96/357 29.03.2014), 2014/30/UE (Official Journal of the UE L 96/79 29.03.2014), 2011/65/UE, 2009/125/EC